

# PRODUCT INFORMATION PACKET

Model No: 056T34D5371  
Catalog No: J053  
3,3450,DP,56HJ,3/60/208-230/460  
Three Phase



Regal and Marathon are trademarks of Regal Beloit Corporation or one of its affiliated companies.  
©2018 Regal Beloit Corporation, All Rights Reserved. MC017097E





### Nameplate Specifications

Output HP	<b>3 Hp</b>	Output KW	<b>2.2 kW</b>
Frequency	<b>60 Hz</b>	Voltage	<b>208-230/460 V</b>
Current	<b>8.9-8.4/4.2 A</b>	Speed	<b>3450 rpm</b>
Service Factor	<b>1.15</b>	Phase	<b>3</b>
Efficiency	<b>84 %</b>	Duty	<b>Continuous</b>
Insulation Class	<b>B</b>	Design Code	<b>B</b>
KVA Code	<b>J</b>	Frame	<b>56HJ</b>
Enclosure	<b>Drip Proof</b>	Overload Protector	<b>No</b>
Ambient Temperature	<b>40 °C</b>	Drive End Bearing Size	<b>6205</b>
Opp Drive End Bearing Size	<b>6203</b>	UL	<b>Recognized</b>
CSA	<b>Y</b>	CE	<b>Y</b>
IP Code	<b>22</b>		

### Technical Specifications

Electrical Type	<b>Squirrel Cage Induction Run</b>	Starting Method	<b>Across The Line</b>
Poles	<b>2</b>	Rotation	<b>Reversible</b>
Mounting	<b>Rigid base</b>	Motor Orientation	<b>Horizontal Or Shaft Down</b>
Drive End Bearing	<b>Ball</b>	Opp Drive End Bearing	<b>Ball</b>
Frame Material	<b>Rolled Steel</b>	Shaft Type	<b>J</b>
Overall Length	<b>11.93 in</b>	Frame Length	<b>7.56 in</b>
Shaft Diameter	<b>0.625 in</b>	Shaft Extension	<b>2.57 in</b>
Assembly/Box Mounting	<b>F1 Only</b>		
Outline Drawing	<b>A-100815-756</b>	Connection Diagram	<b>A-EE7308</b>

This is an uncontrolled document once printed or downloaded and is subject to change without notice. Date Created: 06/29/2018

100815

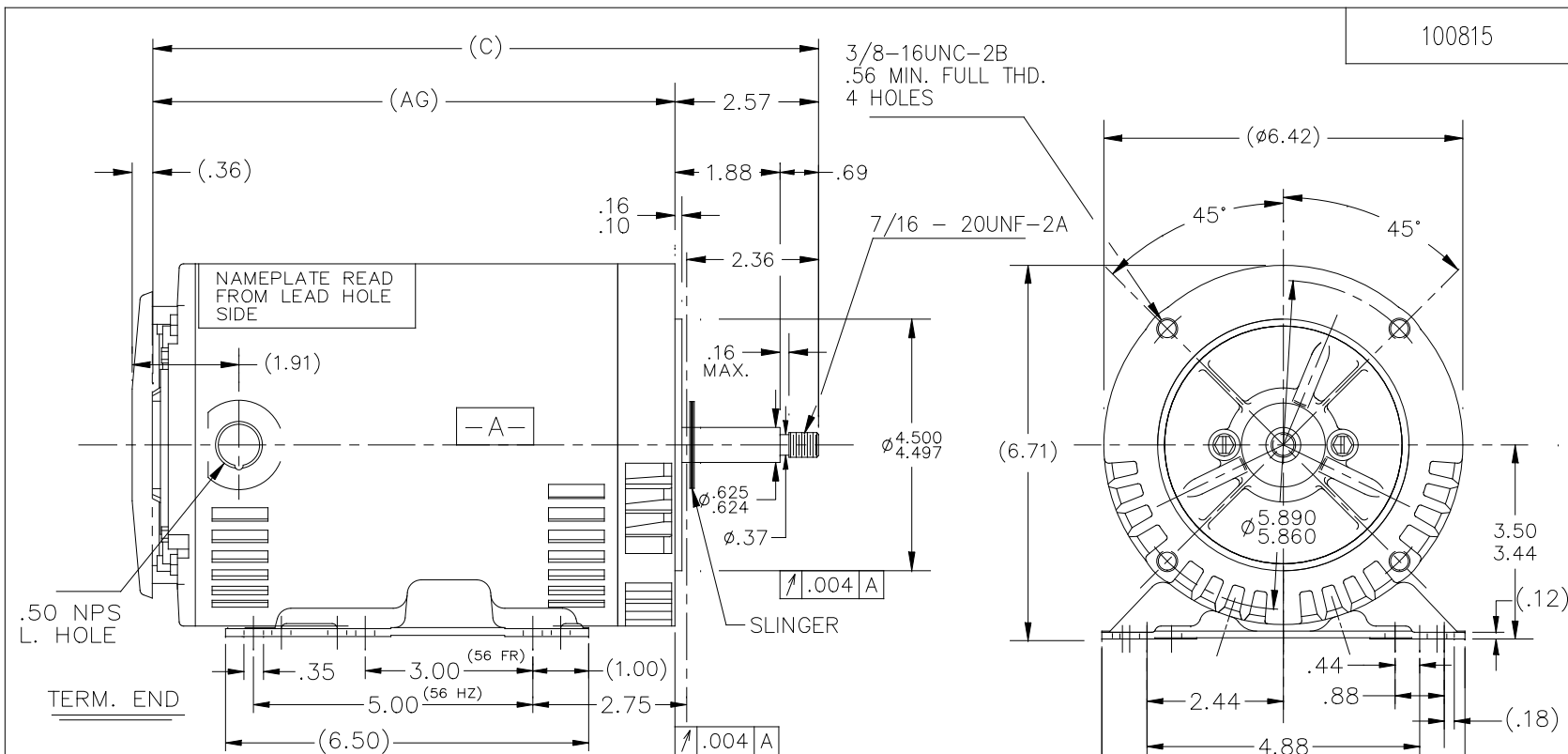

DASH	FR.	C	AG		DASH	FR.	C	AG	
606	56-60	10.43	7.86		806	56-80	12.43	9.86	
656	"-65	10.93	8.36		856	"-85	12.93	10.36	
706	"-70	11.43	8.86		906	"-90	13.43	10.86	
756	"-75	11.93	9.36		956	"-95	13.93	11.36	

				TOLERANCES UNLESS SPECIFIED		 <b>Regal Beloit America, Inc.</b>		DRAWN KL 09-27-1993	
				DEC.	INCHES			CHK ML 09-27-1993	
				.X	±.1			APPD GK 09-27-1993	
				.XX	±.03			SCALE 3=8	
				.XXX	±.005	TITLE OUTLINE		REF	
F	REDRAWN IN CAD	SM	5/17/2017	SM	.XXXX	±.0005	56 FR - BB - DR.PR. - C'FACE - 3φ		FMF
NO.	REVISION	BY & DATE		CHK	ANG	±7'30"	FINISH		PREV
THIS DRAWING IN DESIGN AND DETAIL IS OUR PROPERTY AND MUST NOT BE USED EXCEPT IN CONNECTION WITH OUR WORK ALL RIGHTS OF DESIGN AND INVENTION ARE RESERVED THIS IS AN ELECTRONICALLY GENERATED DOCUMENT - DO NOT SCALE THIS PRINT				RFP	CAD FILE 100815			SIZE	DRAWING NO. PAGE OF REV.
				DIST	WP			A	100815 F

EE7308

THREE PHASE  
DUAL VOLTAGE MOTOR

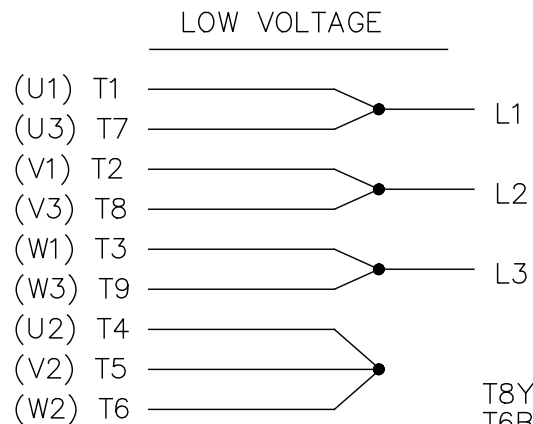
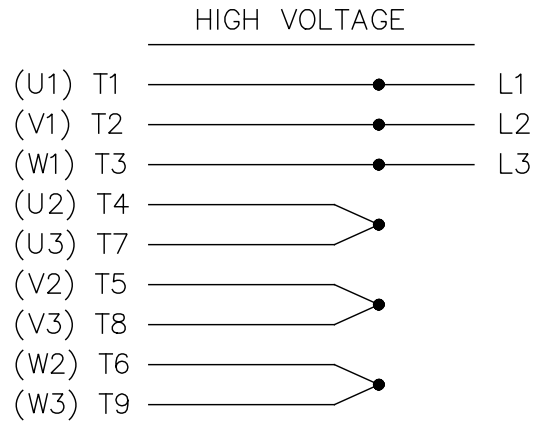

VIEW OF TERMINAL END

REF.  
WINDING DIAGRAM

T8Y, T2Y, T2BL, T4BX, T2EC, T2G  
T6BZ, T2B, T6BL, T4AV, T6B, T4B

OPTIONAL CORD  
CONNECTION

L1 — WHITE  
L2 — RED  
L3 — BLACK

NO.	REVISION	BY & DATE	CHK	ANG	TOLERANCES UNLESS SPECIFIED	FINISH	PREV
5	CHG TO REGAL LOGO	SL 09/10/2015	AB	DEC.	INCHES		
4	REVISED IEC NOTATIONS	MSG 11/15/2011	CMN	.X	±.1		
3	ADDED IEC NOTATIONS... (U1), (V1) ETC. MU95194	MSG 5/10/2010	MJS	.XX	±.02		
2	ADDED THE OPTIONAL CORD CONNECTION MU46318	RDH 04/24/2003	DRS	.XXX	±.005		
1	REDRAWN	RM 11/20/1990		.XXXX	±.0005		
					±7'30"		
THIS DRAWING IN DESIGN AND DETAIL IS OUR PROPERTY AND MUST NOT BE USED EXCEPT IN CONNECTION WITH OUR WORK ALL RIGHTS OF DESIGN AND INVENTION ARE RESERVED THIS IS AN ELECTRONICALLY GENERATED DOCUMENT - DO NOT SCALE THIS PRINT						RFP	
						DIST WP	
						CAD FILE ee7308	
						SIZE A	
						DRAWING NO. EE7308	
						PAGE OF 5	
						REV. 5	

**REGAL**™ Regal Beloit America, Inc. DRAWN RM 11/20/1990  
CHK ML 11/21/1990  
APPD SAS 04/24/2003

TITLE CONNECTION DIAGRAM  
3Ø - DUAL VOLTAGE MOTOR SCALE 1=1  
REF

MAT'L. FMP

**CERTIFICATION DATA SHEET**

Model#: 56T34D5371 D WINDING#: ZT201 DR 3  
 CONN. DIAGRAM: A-EE7308 ASSEMBLY: F1 ONLY  
 OUTLINE: A-100815-756

**TYPICAL MOTOR PERFORMANCE DATA**

HP	KW	SYNC. RPM	F.L. RPM	FRAME	ENCLOSURE	KVA CODE	DESIGN
3&2	2.24&1.49	3600	3450&2850	56HJ	DP	J	B

PH	Hz	VOLTS	FL AMPS	START TYPE	DUTY	INSL	S.F	AMB°C	ELEVATION
3	60/50	208- 230/460#190/ 380	8.9- 8.4/4.2&7/3.5	ACROSS THE LINE	CONTINUOU S	B3	1.15/1.15	40	3300

FULL LOAD EFF: 84&84	3/4 LOAD EFF: 84	1/2 LOAD EFF: 82.5	GTD. EFF	ELEC. TYPE	NO LOAD AMPS
FULL LOAD PF: 82&81	3/4 LOAD PF: 76	1/2 LOAD PF: 65	81.5	SQ CAGE IND RUN	4 / 2

F.L. TORQUE	LOCKED ROTOR AMPS	L.R. TORQUE	B.D. TORQUE	F.L. RISE°C
4.5 LB-FT	60 / 30	10 LB-FT 222	15 LB-FT 333	65

SOUND PRESSURE @ 3 FT.	SOUND POWER	ROTOR WK^2	MAX. WK^2	SAFE STALL TIME	STARTS /HOUR	APPROX. MOTOR WGT
68 dBA	78 dBA	0.04 LB-FT^2	5 LB-FT^2	8 SEC.	2	32 LBS.

**\*\*\* SUPPLEMENTAL INFORMATION \*\*\***

DE BRACKET TYPE	ODE BRACKET TYPE	MOUNT TYPE	ORIENTATION	SEVERE DUTY	HAZARDOUS LOCATION	DRIP COVER	SCREENS	PAINT
C-FACE	STANDARD	RIGID	HORIZONTAL OR SHAFT DOWN	FALSE	NONE	TRUE	NONE	GRAY (POWDER)

BEARINGS		GREASE	SHAFT TYPE	SPECIAL DE	SPECIAL ODE	SHAFT MATERIAL	FRAME MATERIAL
DE	OPE						
BALL	BALL	POLYREX EM	JET PUMP	NONE	NONE	416 STAINLESS (C-503)	ROLLED STEEL
6205	6203						

THERMO-PROTECTORS				THERMISTORS	CONTROL	SPACE /n HEATERS
THERMOSTATS	PROTECTORS	WDG RTDs	BRG RTDs			
NONE	NOT	NONE	NONE	NONE	FALSE	NONE VOLTS

If Inverter equals NONE, contact factory for further information

INVERTER TORQUE: NONE
INV. HP SPEED RANGE: NONE
ENCODER: NONE
NONE NONE
NONE NONE PPR
BRAKE: NONE NONE
NONE P/N NONE
NONE NONE
NONE FT-LB NONE V NONE Hz

\*  
N  
O  
T  
E  
S  
\*

\*\* Subject to change without notice.